

Theoretical Geometric Probability: Ratio of successful outcomes to possible outcomes related to areas and lengths.

$$\text{Probability} = \frac{\text{Area of Desired Region}}{\text{Total Area}}$$

Circle:
 $A = \pi r^2$

Square/Rectangle:
 $A = l \cdot w$

Sector of a Circle:
 $A = \frac{\theta}{360} \cdot \pi r^2$

Triangle:
 $A = \frac{1}{2}bh$ or $A = \frac{1}{2}absinC$

Example: A desk is 29 inches wide and 60 inches long. On it is a desk pad that is 17 inches wide and 22 inches long. If a person randomly flips a paperclip on the desk, what is the probability that it will land on the desk pad?

Find the probability that a point chosen at random will land in the shaded area.

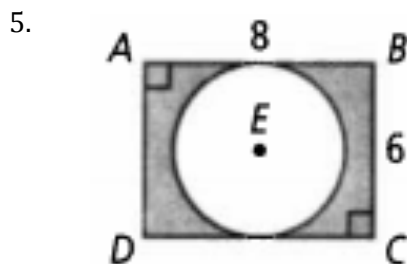
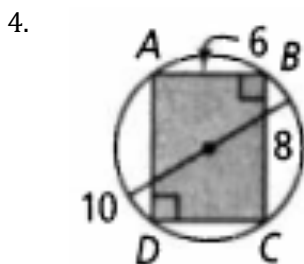
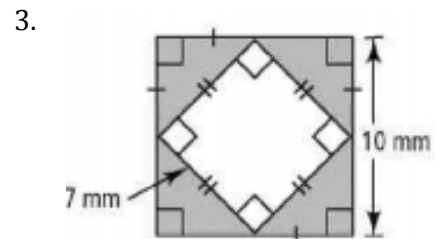
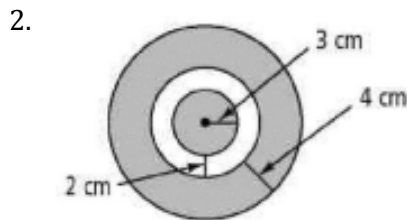
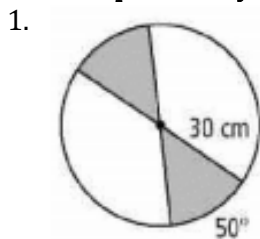

7.

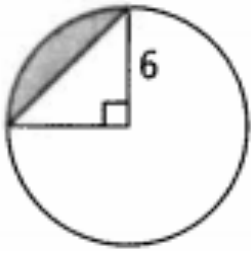

8.

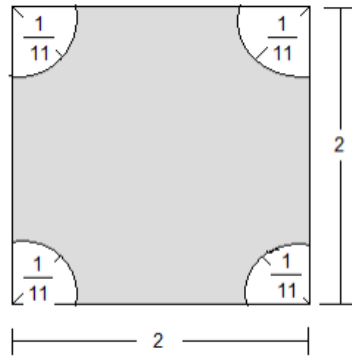

9.

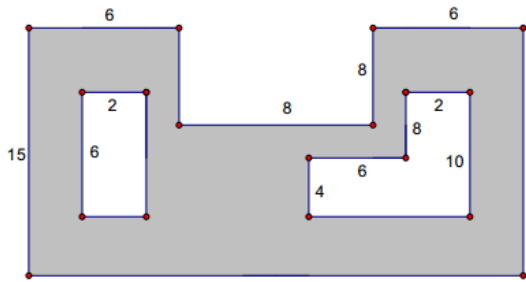

10. a. What is the probability of hitting region X?

b. What is the probability of hitting region Y?

c. What is the probability of hitting region Z?

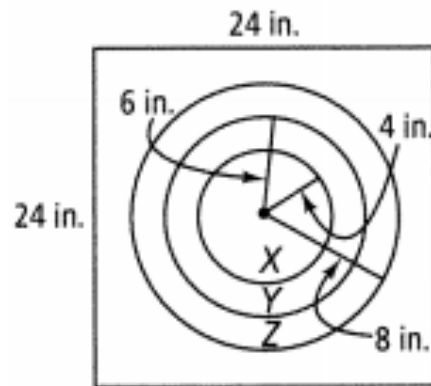

11. You and your friend are playing a target game based on the board to the right. You must hit the border to win a point. Your friend must hit the circle in the center.

a. Is this game fair? That is, do you or your friend have an equal probability of hitting your target zone? Explain.

b. Find the radius of the circle that would make this game fair.

c. Find the probability that you do not score a point.

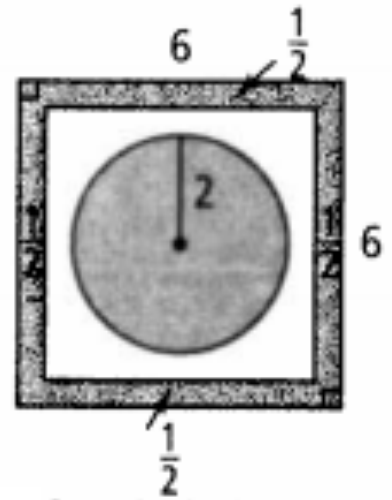

12. In the fundraiser game at the right, players toss darts at a board to try to get them into one of the holes. The diameter of the center hole is 8 in. The diameter of each of the four corner holes is 5 in. The board is a 20 in. by 30 in. rectangle. Find the probability that a tossed dart will go through the indicated hole.

a. center hole

b. top right or left corner

c. any corner

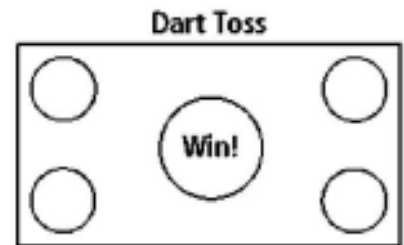

Round all probabilities to the nearest tenth of a percent.



1. A rectangular field measures 27 feet by 15 feet. Find the area of the field.
2. A small shed is on the field. Its dimensions are 8 feet by 10 feet. What is its area?
3. What is the probability that a single drop of rain that lands in the field would hit the shed?
4. What is the probability that a single drop of rain that lands in the field would *not* hit the shed?
5. There is a large oak tree in one corner whose branches have a diameter of 20 feet. What is the probability that a single drop of rain that lands in the field would miss both the shed and the tree? (Assume the shed is not under the tree.)

A dartboard is made up of concentric circles with the following radii:

Circle A: $r = 2$ inches

Circle B: $r = 4$ inches

Circle C: $r = 6$ inches

Circle D: $r = 10$ inches

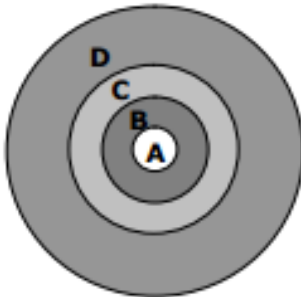

6. Find the area of circle A.
7. Find the area of circle B that is *not* covered by circle A.
8. Find the area of circle C that is *not* covered by circle A or B.
9. Find the area of the dartboard that is *not* covered by circles A, B, or C.

The circles on the dartboard are painted on a rectangular piece of corkboard that is 2 feet by 30 inches. Find the probability of each event, assuming the dart always lands on the corkboard.

10. A random dart lands on one of the circles.
11. A random dart lands on circle C or D.
12. A random dart will make a bull's-eye.
13. A random dart falls only on circle C.